

**BEFORE THE FORUM**  
**FOR REDRESSAL OF CONSUMER GRIEVANCES**  
**IN SOUTHERN POWER DISTRIBUTION COMPANY OF A.P LIMITED**  
**TIRUPATI**

**On this the 28<sup>th</sup> day of October 2013**

**In C.G.No: 94/ 2013-14/ Ongole Circle**

***Present***

***Sri K. Paul***  
***Sri A. Venugopal***  
***Sri T. Rajeswara Rao***  
***Sri A. Satish Kumar***

***Chairperson***  
***Member (Accounts)***  
***Member (Legal)***  
***Member (Consumer Affairs)***

***Between***

Sri. S.Harish Kumar  
C/o Vodafone Representative  
Nagarajukunta Village & Post,  
Konakanamitta,  
Prakasam-Dist

Complainant

***And***

1. Assistant Engineer/Operation/Konakanamitta
2. Assistant Divisional Engineer/Operation/Rural-1/Podili
3. Assistant Divisional Engineer/DPE/Ongole
4. Divisional Engineer/Operation/Kanigiri.

Respondents

\*\*\*

Sri. S.Harish Kumar, C/o Vodafone Representative resident of Munagapadu Nagarajukunta Village & Post, Konakanamitta, Prakasam-Dist herein called the complainant, in his complaint dt:20-06-2013 filed in the Forum on dt:20-06-2013 under clause 5 (7) of APERC regulation 1/2004 read with section 42 (5) of I.E. Act 2003 has stated that

1. He is representing Vodafone services and having service connection number 412222800313 at Nagarajukunta village of KK.Mitta mandal in Prakasam-Dist.
2. His service above was inspected by one M.Bhaskar Rao, ADE/DPE-II and during his inspection he is stated that there is a total connected

load of 24180 watts, out of which the power interface unit having 12000 wattage is far changing over the loads from APSPDCL supply to the Genset supply in the event of failure of APSPDCL supply and otherwise.

3. They are having 15KW contracted load and the total connected load is 12.180 KW only leaving the power interface unit and their usage is within the approved contracted load.
4. Requested to re-inspect the service and remove the power interface unit from the total load.

**The respondent-3, i.e. the Assistant Divisional Engineer/Operation/ Podili in his written submissions dt: 12-07-2013, received in this office on 24-07-2013 stated that:**

**SKETCH :**

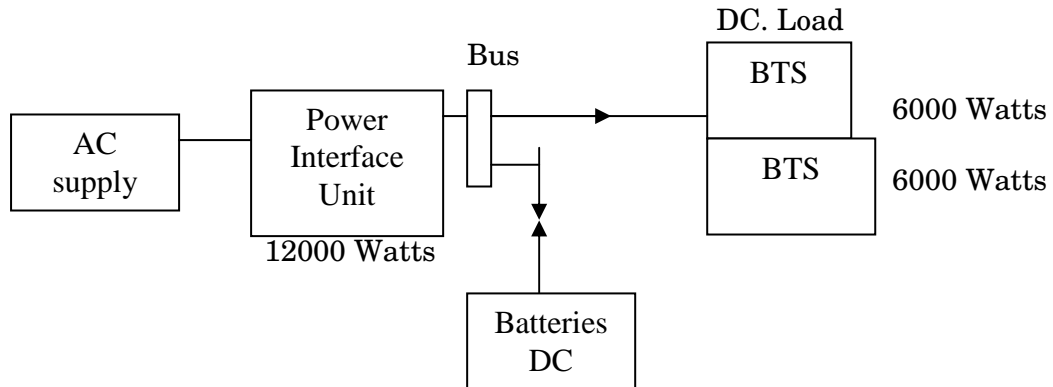

1. On verification it is noticed that, the item wise quantities/capacitors are same as that of inspection notes of ADE/DPE-II/Ongole.
2. The equipment like, power interface unit, batteries are connected. The recorded maximum demand is in the order of 06KVA.

**The respondent-5, i.e. the Assistant Divisional Engineer/DPE-II/Ongole in his written submissions dt: 06-09-2013, received in the Forum on 17-09-2013 stated that:**

1. He had inspected the ScNo:313 of Nagarajukunta distribution on 10-01-2013 and the PA notice was issued by the ADE/Opn/Podili on 25-01-2013
2. At the time of his inspection Sri M.Sekhar Reddy the Supervisor for the cell tower unit was present and witnessed the inspection and attested the inspection notes.
3. The contention of the complainant that the load of power interface unit is nil is not accepted because the batteries are charged from the APSPDCL supply only. Hence the load of power interface unit is considered as connected load and accordingly inspection report is prepared.

**Findings of the Forum:**

1. The grievance of the complainant is that the inspecting officer of the licensee mistook the loads connected to the system related to transmission tower of Vodafone services stating that there is an additional load over and above the contracted load of 15KW and requested to re-inspect their service and reassess the load.
2. The respondent-2 i.e. the ADE/Opn/Podili while enclosing a sketch of the electrical layout stated that the item wise quantities/capacities are same as that of inspection notes of ADE/DPE-2/Ongole and the recorded maximum demand was of the order of 6 KVA.
3. The respondent-5 i.e. the ADE/DPE-II/Ongole in his reply stated that he had inspected the premises of the complainant with ScNo:313, Nagarajukunta on 10-01-2013 and the PA notice was issued by the respondent-2 the ADE/Operation concerned on 25-01-2013.

4. The main contention of the complainant that the load of the power interface unit is nil is not accepted by him in view of the batteries also are charges from the supply given by APSPDCL.
5. As per the inspection notes the total connected load was 24.18KW while the contracted load was 15KW only and hence there is an additional load of 9.18KW to be considered as 10KW for regularization.
6. Also, as could be seen from the sketch, the loads incidental on the AC supply of the licensee are the power interface unit of 12000 watts (12 KW maximum capacity) and the battery unit totaling to a load of 24.18KW which is in coincidence with the statement given by the inspecting officer herein the ADE/DPE-II/Ongole.
7. In accordance with the clause no. 12.3.3.1 as amended by the honourable APERC on 07-03-2012 the consumer herein the complainant shall be given opportunity to remove any additional load i.e. not required by him or to regularize the load as per his requirement by paying the necessary charges of development and security within a period of one month upon receipt of such notice.
8. As such in this case also the complainant shall be allowed a period of one month upon giving a fresh notice to that effect and wait till the said period expires.

In view of the above, the Forum passed the following order.

**ORDER**

The respondents are directed that they

1. shall revise the notice already issued for the amount of Rs.32,150/- with immediate effect for the said additional load of 9.18KW already issued and a fresh notice shall be issued to the consumer with an

option to remove any unnecessary loads as per his requirement within a period of one month from the date of receipt of the notice.

2. shall re-inspect the service after expiry of the above said one month period and issue a notice for regularization for the excess load if any noticed at the time of second inspection.
3. shall report compliance on the item-1 and 2 above within 45 days from the date of this order.

Accordingly the case is allowed and disposed off

If aggrieved by this order, the complainant may represent to the Vidyut Ombudsman, O/o the APERC, 5<sup>th</sup> floor, Singarenibhavan, Redhills, Hyderabad-500004, within 30 days from the date of receipt of this order.

Signed on this the 28<sup>th</sup> day of October 2013.

Sd/-  
**Member (Legal)**

Sd/-  
**Member (C.A)**

Sd/-  
**Member (Accounts)**

Sd/-  
**Chairperson**

**Forwarded by Orders**

**Secretary to the Forum**

To  
The Complainant  
The Respondents  
Copy to the General Manager/CSC/Corporate office/Tirupati for pursuance in this matter.